

YVWH

Premium-efficiency VSD water-cooled screw compressor chiller

Cooling capacity: 313 kW to 1189 kW (R1234ze) – 1566 kW (R134a)

Heating capacity: 315 kW to 1250 kW (R1234ze) – 1730 kW (R134a)

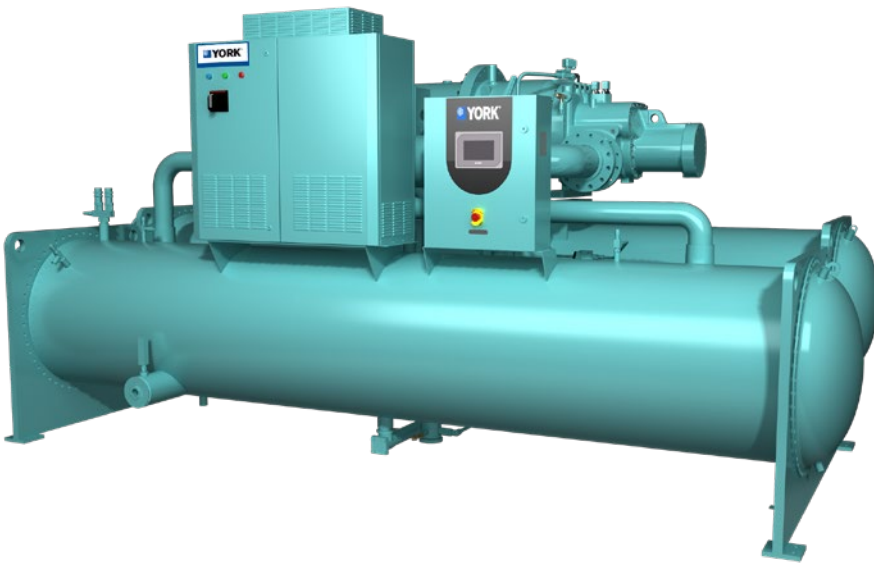

Features

YVWH is innovatively designed and manufactured, it offers **premium efficiency** at both full load and part load condition, helping the customer achieving the greatest value. Thanks to the combination of high efficiency and the use of the new 4th generation **HFO refrigerant R1234ze**, the chiller SEER surpasses the Ecodesign Tier 2 requirement and contributes to the reduction of the CO2 emissions.

Key components

- Optimized motor and flow structure design ensure high compressor efficiency
- Optimized compressor with variable Vi design further enhances partload performance
- Built-in condenser oil separator increases the oil separation effectiveness
- Counterflow subcooler design provides the most optimized subcooling

Committed to sustainability

- Low GWP solution with new refrigerant R1234ze (GWP = 7, F-Gas)
- R1234ze and R134a refrigerants protect the ozone layer (ODP = 0) and have no phase out date
- Chiller SEER exceeding by far Ecodesign Tier 2 requirements
- Premium chiller efficiency brings green building effectiveness to a remarkable level

Options/Accessories

- Heat pump up to **50°C** water production, with R1234ze
- Spring isolators
- Left/right pipe connection
- Sound kit up to 10 dB(A) reduction
- Thicker evaporator insulation
- Refrigerant isolation valve
- Harmonic filter

Premium-efficiency VSD water-cooled screw compressor chiller

YVWH 115 to 445



Performances (R1234ze)

YVWH		115	145	180	225	265	305	325	380	445	
Cooling capacity	kW	313.3	389.3	481.5	602.1	721.7	799.7	882.8	1033.0	1189.0	
Optimized compressor (Variable Vi)	EER	6.23	6.41	6.19	6.41	6.25	6.25	6.07	6.24	6.13	
	SEER	8.61	8.81	8.85	9.13	9.31	9.31	9.68	10.01	9.82	
	η_{sc}	341.44	349.57	351.17	362.27	369.36	369.36	384.34	397.44	389.9	
Evaporator	Pass	4				2					
	Flow rate	l/s	15.00	19.23	23.56	28.82	33.11	39.63	42.22	49.54	58.71
	Piping dimension	mm	125		150		200				
	Pressure drop	kPa	44.5	53.6	53.3	51.6	43.0	37.2	19.6	27.1	32.8
Condenser	Pass	4				2					
	Flow rate	l/s	17.56	22.42	27.55	33.61	38.75	46.18	49.53	57.87	68.74
	Piping dimension	mm	125		150		200				
	Pressure drop	kPa	43.6	52.6	52.4	52.4	45.9	32.7	21.7	24.5	34.3
Refrigerant circuit	n.					1					
Compressor quantity	n.					1					
Capacity control %		15-100%									
Refrigerant charge	kg	200		240	250	360	370	400	410	510	
Sound pressure level (1m) ¹	dBA	78	80	82	84	80	85	87	89	91	

Ratings in accordance to Ecodesign, variable water flow and variable outlet (VW/VO). Rated with YORKworks 21.04a.

For other Ecodesign calculations or R134a information, please contact your JCI Representative.

¹ Bare unit. Sound kit 1 or 2 are available for sound attenuation.

Technical data

YVWH		115	145	180	225	265	305	325	380	445
Dimensions	Length	mm	3118	3131	3154	3156	4807	4832	4873	
	Width	mm	1710	1797	1975	2005	1925	1988	2086	
	Height	mm	1966	1996	2124	2250	2300		2320	
Operating weight	kg	4387	5169	6350	6951	7834	8894	9306	9983	

Soft Start

YVWH provides a soft start without current shock. The start-up current will never be larger than the rating current, which benefits the customer with lower cost on associated equipment and smaller backup generator and quick start function in case of the shutdown due to power supply failure.

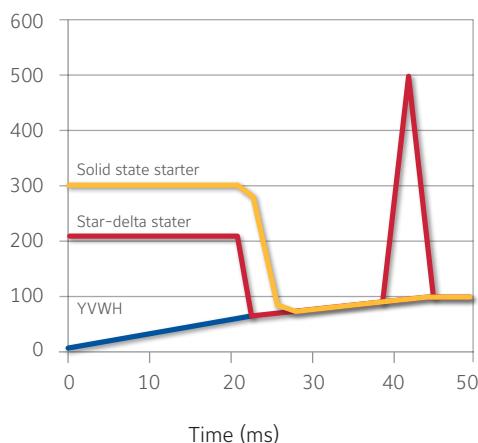

Displacement Power Factor (DPF)

The Variable Speed Drive (VSD) design makes 0.95 high DPF achievable in standard YVWH models at all operating conditions. For traditional non-VSD designed screw chiller, the DPF will reduce when the cooling load goes down.

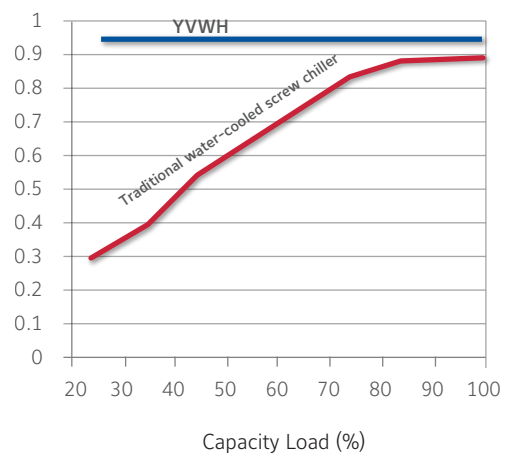

Manufacturer reserves the rights to change specifications without prior notice.

YVWH main features

Variable Vi

Premium efficiency water-cooled screw chillers from YORK® control the refrigerant volume ratio (Vi) to match the pressure ratio, which helps maintain optimum compressor efficiency. YORK® was the first manufacturer to offer this technology, and our step-less control with perfectly matched compressor and system Vi can provide up to 10% SEER performance improvement (average 6% across the range) vs fixed Vi systems.

Performance Improvement by Variable Vi

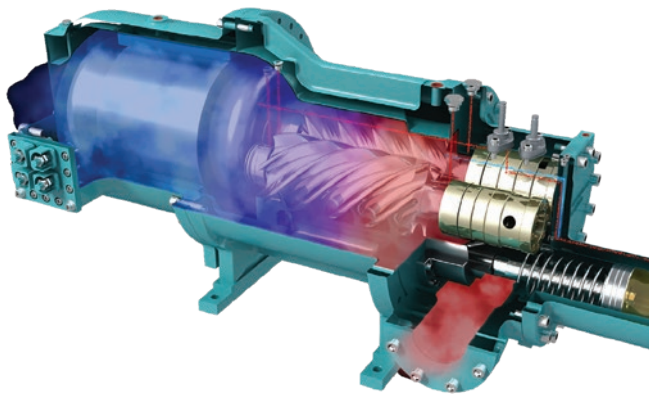
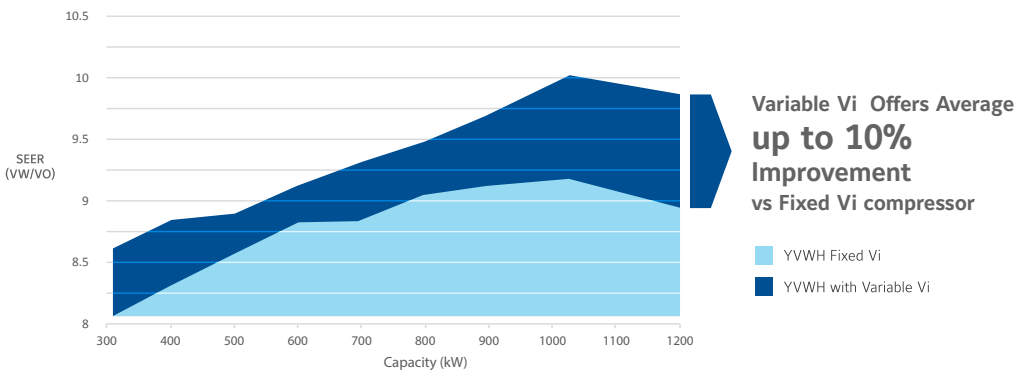

Optimized Compressor

Screw compressors from YORK® use advanced technology to deliver higher efficiencies. Optimized variable volume ratio compressor design matches compression to the load to avoid over-compression and wasted energy. A special rotor design provides a tight seal and high compression efficiency. A compact design with simple assembly provides easier maintenance. Together, these technological enhancements increase efficiency while reducing noise and vibration.

Reduced Sound Pressure Levels (1m)

A unique, patented dampening structure in the YORK® screw compressor is combined with an integrated oil separator to reduce noise. These technologies result in operating sound levels up to 17 dBA quieter than traditional chillers while maintaining peak efficiency.

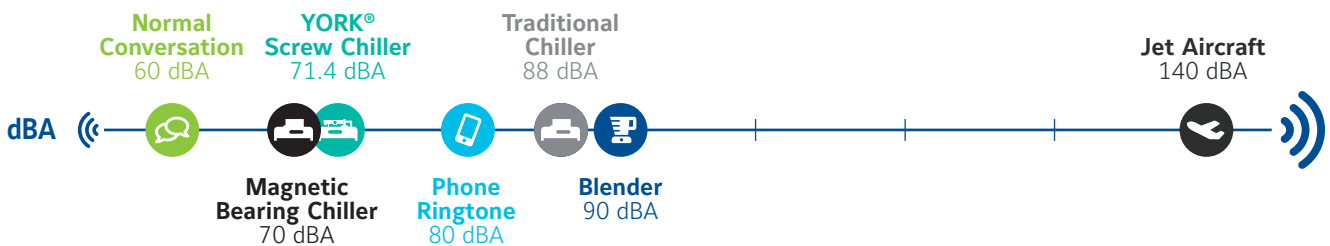

Dimensions and hydraulic connections

YVWH 115/145/180/225

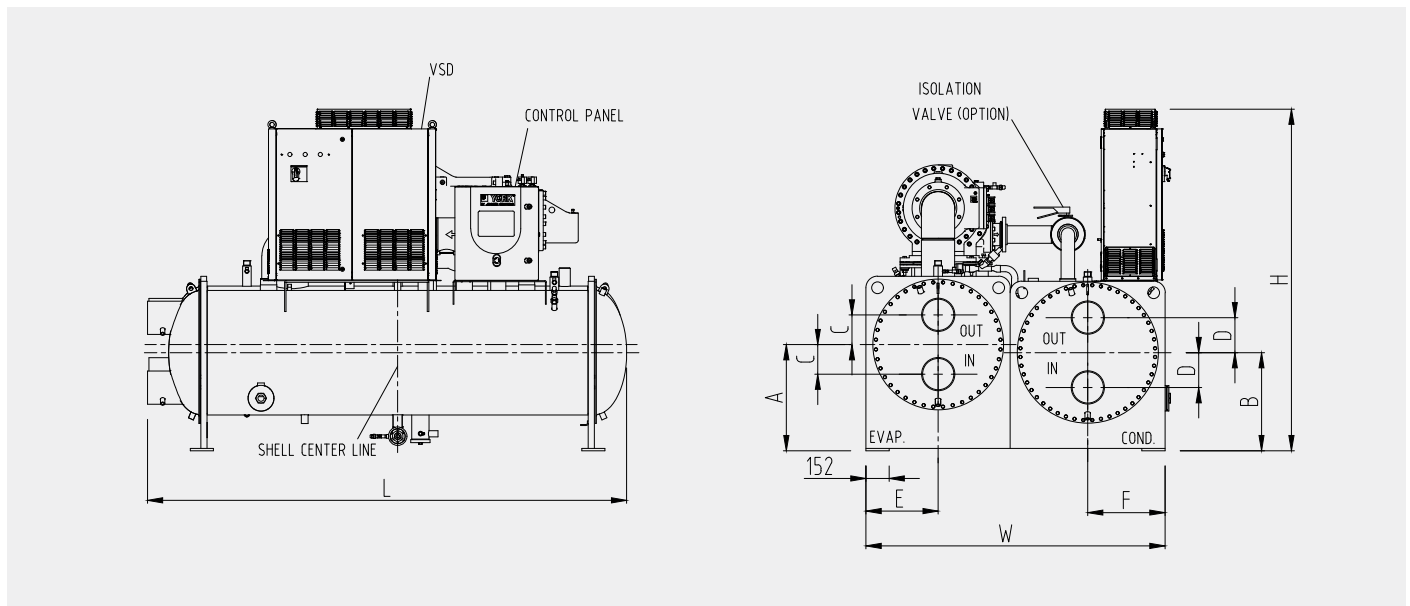

Model	L (mm)	W (mm)	H (mm)	A (mm)	B (mm)	C (mm)	D (mm)	E (mm)	F (mm)
YVWH115	3118	1710	1966	644	566	190	180	400	435
YVWH145	3131	1797	1996	694	586	165	180	425	450
YVWH180	3154	1975	2124	709	646	230	230	460	520
YVWH225	3156	2005	2250	699	646	230	230	475	510

All dimensions in mm. Drawings not in scale.

YVWH 265/305/325/380/445

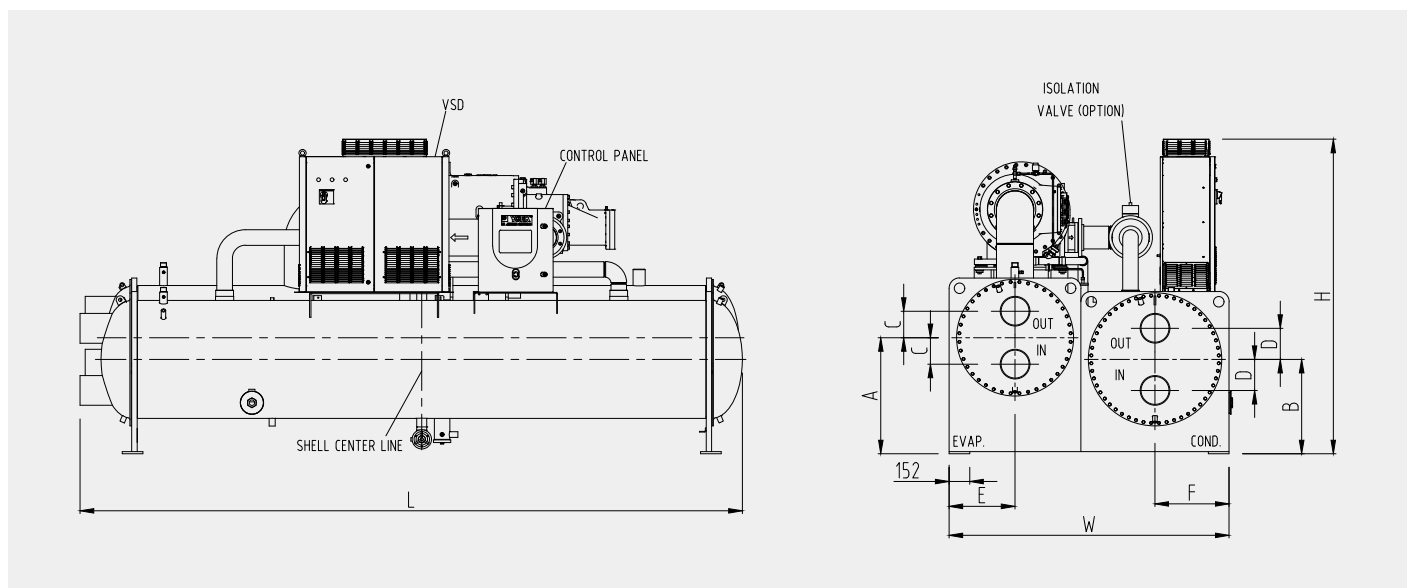

Model	L (mm)	W (mm)	H (mm)	A (mm)	B (mm)	C (mm)	D (mm)	E (mm)	F (mm)
YVWH265	4807	1925	2300	856	696	195	195	460	485
YVWH305	4832	1988	2300	856	696	195	230	460	520
YVWH325/380/445	4873	2086	2320	856	696	195	229	485	545

All dimensions in mm. Drawings not in scale.